

LEYLA Fixations-System
LEYLA Fixation System
LEYLA système de fixation
LEYLA sistema de fijación
LEYLA sistema da fissaggio

40.220.01

Kugelgelenk-Kloben
 Ball and socket joint, articulated
 Sabot pour fixer le bras, articulé
 Zapato para la fijación del brazo, zrticulado
 Zoccolo per fissare il braccio, articolato

40.220.02

Haltearm
 Holding rod for fixation
 Bras de fixation
 Brazo de fijación
 Braccio di fissaggio

40.220.03

Kupplungskopf für max. 5 Spannarme
 Coupling head for 5 flexible arms max.
 Piece de combinaison pour 5 bras flexibles max.
 Pieza de combinación para 5 brazos máx.
 Pezzo per combinare 5 bracci mass.

40.220.04

Kupplungskopf drehbar
 Coupling head rotatable
 Piece de combinaison rotative
 Pieza de combinación giratoria
 Pezzo per combinare girevole

40.222.02

LEYLA Retractor Set 2 (2 Arme) zur Montage an Seitenschiene
 best. aus: **40.220.01, 40.220.02, 40.220.03, 40.220.04,**
 2 x **40.220.07, 2 x 40.220.08, 2 x 40.220.09**

LEYLA retractor Set 2 (2 Arms) for fixation to OR table siderails
 consisting of: **40.220.01, 40.220.02, 40.220.03, 40.220.04,**
 2 x **40.220.07, 2 x 40.220.08, 2 x 40.220.09**

LEYLA écarteur set 2 (2 bras) pour montage aux rails latéraux
 de la table d'OP
 composé de: **40.220.01, 40.220.02, 40.220.03, 40.220.04,**
 2 x **40.220.07, 2 x 40.220.08, 2 x 40.220.09**

LEYLA separador set 2 (2 brazos) para montar al carril lateral de la
 mesa operatoria
 compuesto de: **40.220.01, 40.220.02, 40.220.03, 40.220.04,**
 2 x **40.220.07, 2 x 40.220.08, 2 x 40.220.09**

LEYLA divaricatore set 2 (2 bracci) per montaggio
 al tavolo di operazione
 composto da: **40.220.01, 40.220.02, 40.220.03, 40.220.04,**
 2 x **40.220.07, 2 x 40.220.08, 2 x 40.220.09**

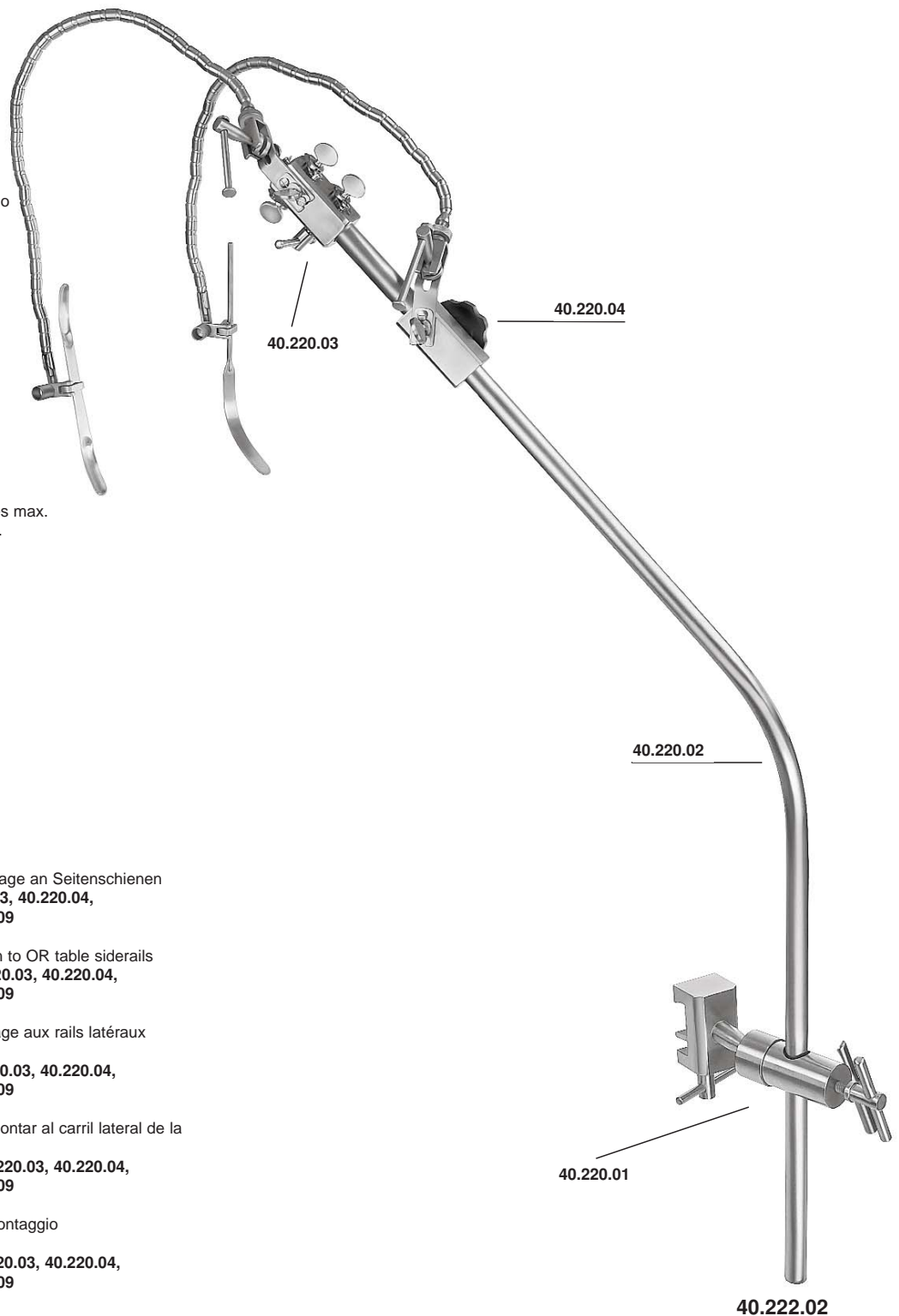

40.220.01

Kugelgelenk-Kloben
Ball and socket joint, articulated
Sabot pour fixer le bras, articulé
Zapato para la fijación del brazo, zrticulado
Zoccolo per fissare il braccio, articolato

40.220.02

Haltearm
Holding rod for fixation
Bras de fixation
Brazo de fijación
Braccio di fissaggio

40.220.03

Kupplungskopf für max. 5 Spannarme
Coupling head for 5 flexible arms max.
Pecce de combinaison pour 5 bras flexibles max.
Pieza de combinación para 5 brazos máx.
Pezzo per combinare 5 bracci mass.

40.221.01

LEYLA Retractor Set 1 (1 Arm)
zur Montage an Seitenschienen
best. aus: **40.220.01, 40.220.02, 40.220.03, 40.220.08, 40.220.09**

LEYLA retractor Set 1 (1 Arm)
for fixation to OR table siderails
consisting of: **40.220.01, 40.220.02, 40.220.03, 40.220.08, 40.220.09**

LEYLA écarteur set 1 (1 bras)
pour montage aux rails latéraux de la table d'OP
composé de: **40.220.01, 40.220.02, 40.220.03, 40.220.08, 40.220.09**

LEYLA separador set 1 (1 brazo)
para montar al carril lateral de la mesa operatoria
compuesto de: **40.220.01, 40.220.02, 40.220.03, 40.220.08, 40.220.09**

LEYLA divaricatore set 1 (1 braccio)
per montaggio al tavolo di operazione
composto da: **40.220.01, 40.220.02, 40.220.03, 40.220.08, 40.220.09**

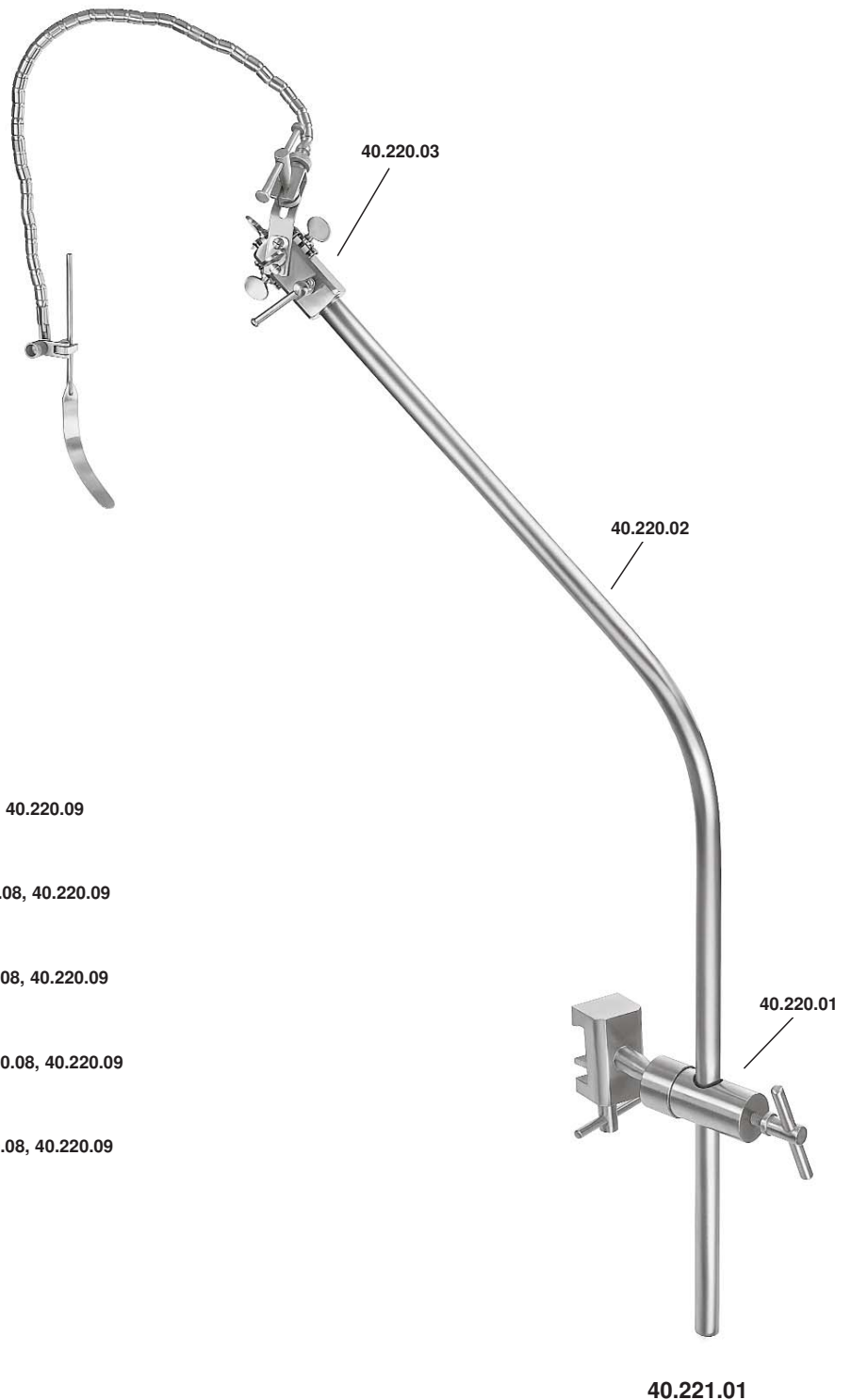

40.221.01

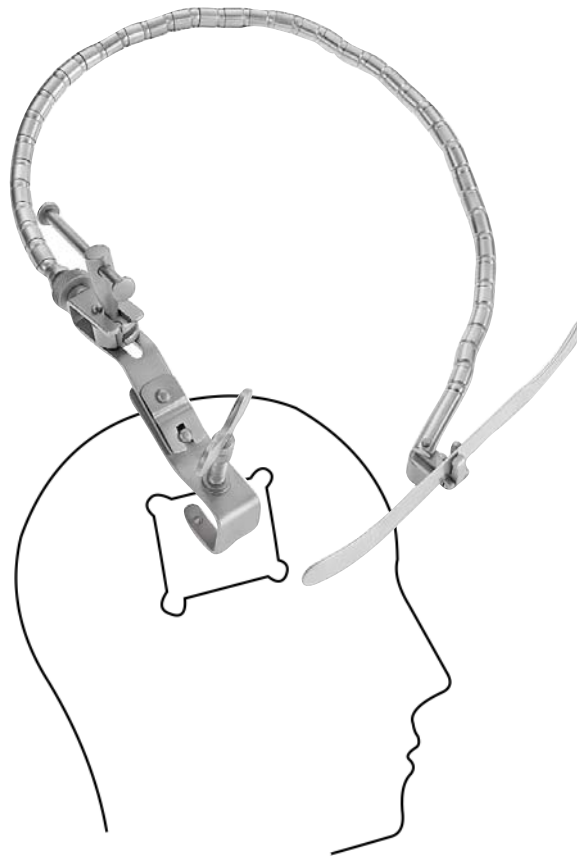

40.221.00

Hirnspatelhalter, selbsthaltend, flexibel,
für flache Spatel,
mit 1 Spannarm, komplett, bestehend aus:
40.220.05, 40.220.08, 40.220.09

Brain retractor, self retaining, flexible,
for flat spatula,
with 1 flexible arm, complete, consisting of:
40.220.05, 40.220.08, 40.220.09

Ecarteur autostatique, flexible,
pour des spatules plates,
avec un bras flexibles, complet, composé de:
40.220.05, 40.220.08, 40.220.09

Separador autorretentivo, flexible,
para espátulas llanas ,
con 1 brazo flexibles, completo, compuesto de:
40.220.05, 40.220.08, 40.220.09

Divaricatore autostatico, flessibile,
per spatole piatte,
con 1 braccio flessibili, completo, composto da:
40.220.05, 40.220.08, 40.220.09

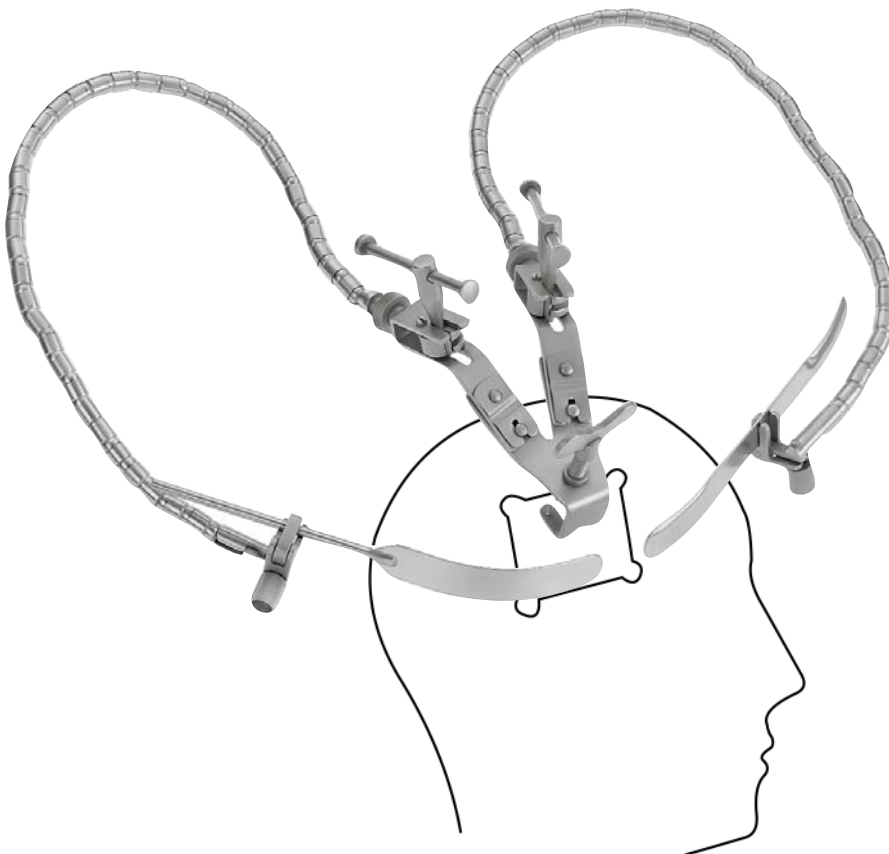

40.222.00

Hirnspatelhalter, selbsthaltend, flexibel,
für flache Spatel,
mit 2 Spannarmen, komplett, bestehend aus:
40.220.06, 2 x 40.220.08, 2 x 40.220.09

Brain retractor, self retaining, flexible,
for flat spatula,
with 2 flexible arms, complete, consisting of:
40.220.06, 2 x 40.220.08, 2 x 40.220.09

Ecarteur autostatique, flexible,
pour des spatules plates,
avec 2 bras flexibles, complet, composé de:
40.220.06, 2 x 40.220.08, 2 x 40.220.09

Separador autorretentivo, flexible,
para espátulas llanas ,
con 2 brazos flexibles, completo, compuesto de:
40.220.06, 2 x 40.220.08, 2 x 40.220.09

Divaricatore autostatico, flessibile,
per spatole piatte,
con 2 bracci flessibili, completo, composto da:
40.220.06, 2 x 40.220.08, 2 x 40.220.09

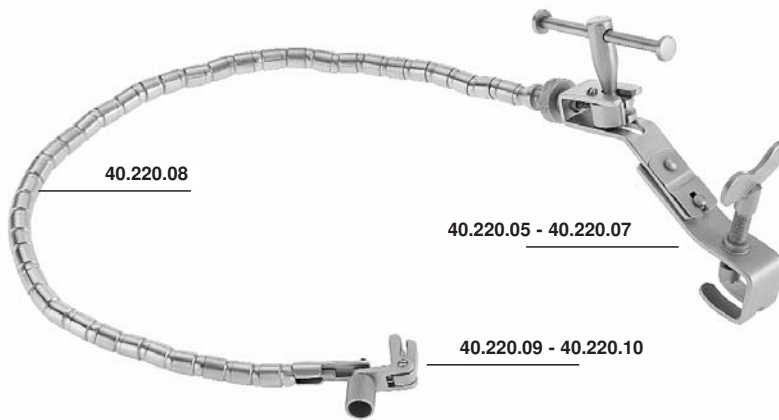

40.220.08

Spannarm allein
 Flexible arm only
 Bras flexible seul
 Brazo flexible suelto
 Braccio flessibile solo

40.220.08

40.220.05 - 40.220.07

40.220.09 - 40.220.10

40.220.05, 40.220.06, 40.220.07

Fixiervorrichtungen für Schädel oder Starrarm
 Fixation bases for skull or rigid holding arm
 Bases pour fixation au crâne ou au bras rigide
 Fijadores para fijación al cráneo o al brazo rígido
 Fissatori per fissaggio al cranio o al braccio rigido



40.220.05

40.220.05

Fixiervorrichtung für 1 Arm zum Festschrauben am Schädel
 Fixation base for 1 arm at skull
 Base de fixation pour 1 bras au crâne
 Fijador para 1 brazo al cráneo
 Fissatore per 1 braccio al cranio

40.220.06

Fixiervorrichtung für 2 Arme zum Festschrauben am Schädel
 Fixation base for 2 arms at skull
 Base de fixation pour 2 bras au crâne
 Fijador para 2 brazos al cráneo
 Fissatore per 2 bracci al cranio



40.220.06

40.220.07

Fixiervorrichtung für 1 Arm zum Festschrauben am Starrarm
 Fixation base for 1 arm at rigid arm
 Base de fixation pour 1 bras au bras rigide
 Fijador para 1 brazo al brazo rígido
 Fissatore per 1 braccio al braccio rigido



40.220.07



40.220.12

Ohrtrichterhalter allein
 Ear specula holder only
 Support pour spéculum auriculaire
 Soporte para espéculo de oídos
 Sostegno per specolo auricolare



40.220.09

Halter für flache Hirnspatel
 Holder for flat brain spatula
 Support pour des spatules plates
 Soporte para espátulas llanas
 Sostegno per spatole piatte



40.220.10

Halter für Hirnspatel mit rundem Schaft
 Holder for brain spatula with round stem
 Support pour des spatules a tige ronde
 Soporte para espátulas con vástago redondo
 Sostegno per spatole con asta rotonda



biegsam
malleable
malléable
maleable
malleabile

CUSHING

40.250.07	7/9 x 180 mm
40.250.11	11/13 x 180 mm
40.250.15	15/18 x 180 mm
40.250.18	18/22 x 180 mm

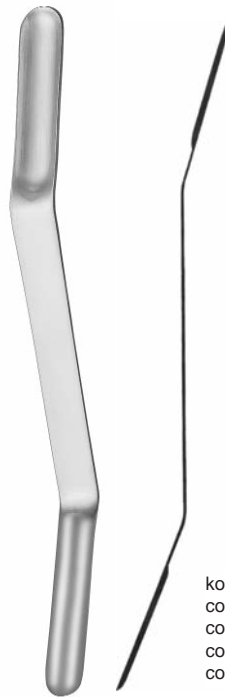

konvex
convex
convexe
convexa
convessa

OLIVECRONA

40.252.13	7/9 x 180 mm
40.252.15	11/13 x 180 mm
40.252.17	15/18 x 180 mm
40.252.19	18/22 x 180 mm

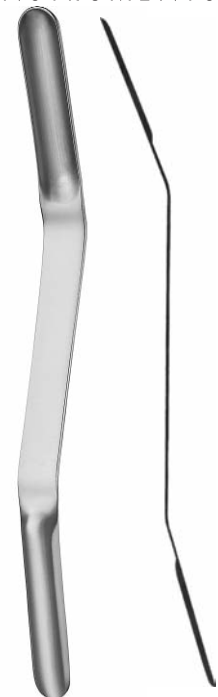

konkav
concave
concave
cóncava
concava

OLIVECRONA

40.253.07	7/9 x 180 mm
40.253.11	11/13 x 180 mm
40.253.15	15/18 x 180 mm
40.253.18	18/22 x 180 mm



biegsam
malleable
malléable
maleable
malleabile

SCOVILLE

40.254.10	10/13 x 200 mm
40.254.16	16/19 x 200 mm



biegsam
malleable
malléable
maleable
malleabile

AACHEN

40.256.07	7/8 x 200 mm
40.256.10	10/11 x 200 mm
40.256.13	13/14 x 200 mm
40.256.16	16/17 x 200 mm
40.256.19	19/20 x 200 mm
40.256.22	22/25 x 200 mm



biegsam
malleable
malléable
maleable
malleabile

40.257.01	9 x 200 mm
40.257.02	12 x 200 mm
40.257.03	12 x 250 mm

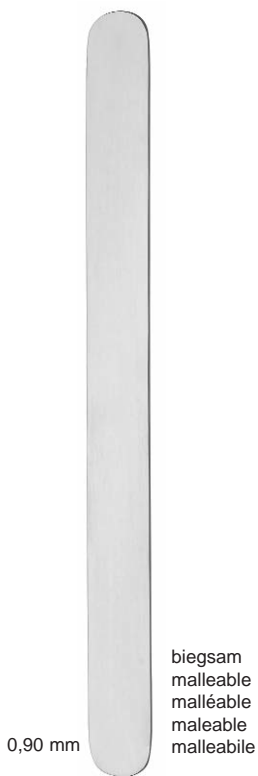

CAIRNS

40.258.06	6 x 200 mm
40.258.08	8 x 200 mm
40.258.10	10 x 200 mm
40.258.11	11 x 200 mm
40.258.13	13 x 200 mm
40.258.16	16 x 200 mm
40.258.19	19 x 200 mm
40.258.25	25 x 200 mm

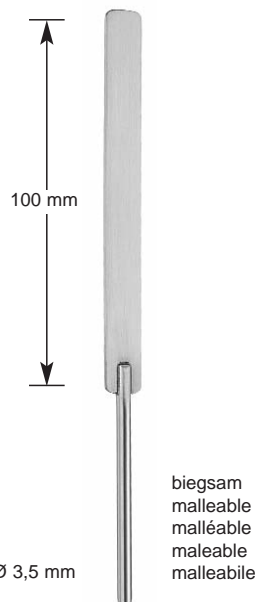

HEIFETZ

40.259.08	8 x 155 mm
40.259.11	11 x 155 mm
40.259.14	14 x 155 mm
40.259.17	17 x 155 mm

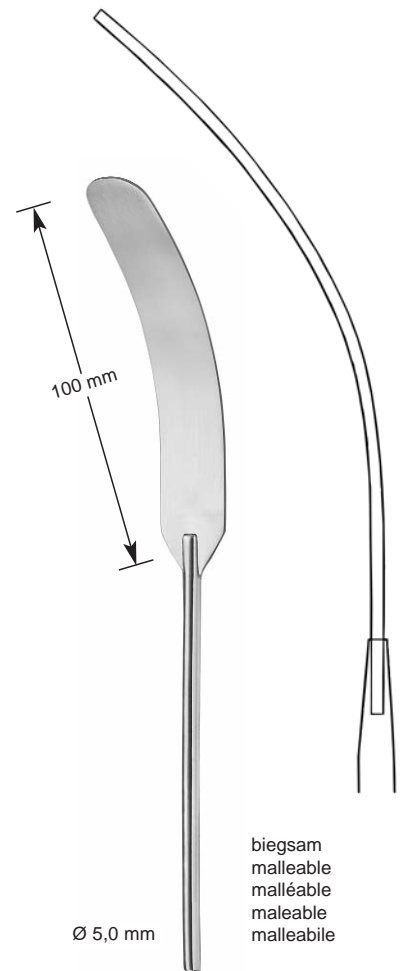

HEIFETZ

40.260.08	8 x 200 mm
40.260.11	11 x 200 mm
40.260.14	14 x 200 mm
40.260.17	17 x 200 mm
40.260.20	20 x 200 mm

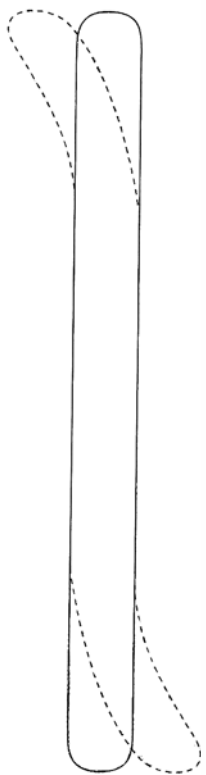

biegsam
malleable
malléable
maleable
malleabile

RIBBON

18.168.06	6 x 200 mm
18.168.07	7 x 200 mm
18.168.09	9 x 200 mm
18.168.12	12 x 200 mm
18.168.17	17 x 200 mm
18.168.20	20 x 200 mm
18.168.24	25 x 200 mm
18.168.25	25 x 250 mm



biegsam
malleable
malléable
maleable
malleabile

RIBBON

18.170.13	13 x 330 mm
18.170.19	19 x 330 mm
18.170.25	25 x 330 mm
18.170.30	30 x 330 mm
18.170.32	32 x 330 mm
18.170.40	40 x 330 mm
18.170.45	45 x 330 mm
18.170.50	50 x 330 mm
18.170.64	64 x 330 mm
18.170.75	75 x 330 mm



biegsam, sehr weich
malleable, very soft
malléable, muy blando
maleable, très souple
malleabile, molto dolci

MARTIN

18.173.06	6,5 x 200 mm
18.173.09	9,5 x 200 mm
18.173.13	13 x 200 mm
18.173.16	16 x 200 mm
18.173.19	19 x 200 mm
18.173.25	25 x 200 mm